



R1-TS

The Reflections Tray Stand is a must to begin your lineup. Its versatile design can provide for all the required utensils. This Reflections unit is compatible and will interlock with other Reflection units. This Tray Stand unit holds virtually all sizes of food trays.

STANDARD FEATURES

- Seamless, molded FRP body with smooth exterior and rounded corners
- 14-gauge stainless steel top with fully welded square turndowns on all sides
- 4" diameter swivel plate casters with brakes
- Interlocking mechanism is provided to interlock with other Reflections units

JOB _____ ITEM # _____ QTY # _____

MODEL NUMBER:

- R1-TS
- R2-TS
- RSD
- RSDN

DIMENSIONS:

- R1-TS - 36"H x 30"D X 28"L
- R2-TS - 36"H x 30"D X 36"L
- RSD - H x D X L
- RSDN - H x D X L

STANDARD COLORS

- Wine Red (RAL 3005)
- Signal Red (RAL 3001)
- Yellow (RAL 1021)
- Light Blue (RAL 5012)
- Gentiane Blue (RAL 5010)
- Water Blue (RAL 5021)
- Moss Green (RAL 6005)
- Squirrel Gray (RAL 7000)
- Black
- White
- Custom colors available
- Optional Graphics Packages available

COMMON OPTIONS

- Bullet feet
- Silverware dispenser
- See reverse side for additional options

WARRANTY

- One year parts and labor. Warranty is detailed on inside front cover of the price list.

SPEC B-12

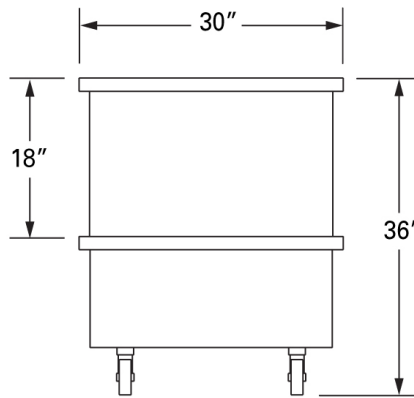
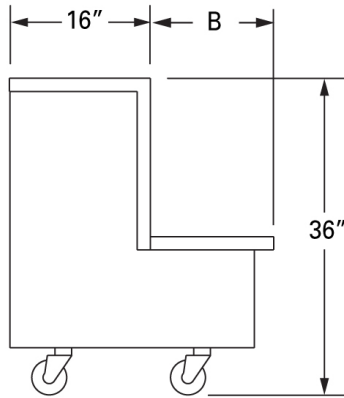
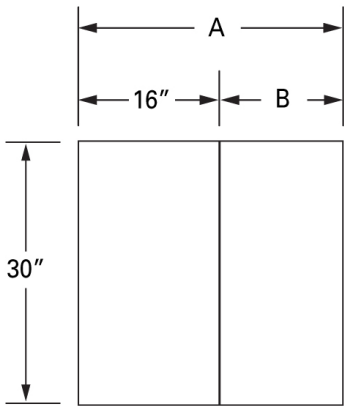

Model #	# of Wells	(A)	(B)	W	H	Ship Wt. (lbs)
R1-TS	Single Tray Stand	28"	12"	30"	36"	155
R2-TS	Double Tray Stand	36"	20"	30"	36"	195
RSD	Silverware Dispenser for Tray Stands w/ 10 Holes					-
RSDN	Silverware & Napkin Dispenser for Tray Stands w/ 8 Holes & 1 Napkin Dispenser					-

R1-TS is single stack, R2-TS is double stack

Petite models are 30" high. Contact factory for details.

Part #	Description	Part #	Description
<input type="checkbox"/> RBL	Stainless steel 6" adjustable bullet feet	<input type="checkbox"/> RSDN	Silverware and napkin dispenser
<input type="checkbox"/> RSD	Silverware dispenser		

SPEC B-12

PIPER

The Food-Focused Equipment Company

300 S. 84th Avenue | Wausau, WI 54401
 Phone: 800-544-3057 | Fax: 715-842-3125
www.piperonline.net

LIMITED WARRANTY: PIPER PRODUCTS warrants to the original purchaser parts and labor for a period of twelve (12) months from the date of purchase. See manufacturer's complete warranty for details.

It is our policy to build equipment which is design certified by companies that have been accredited at the Federal Level by the Occupational Safety and Health Agency (OSHA) and ANSI as a National Recognized Testing Laboratory. These companies include CSA International, Underwriters Laboratories, and the National Sanitation Foundation. However, a continuing program of product improvement makes it necessary to submit new models to the agencies as they are developed. Consequently, all models may not bear the appropriate labels at all times. We reserve the right to change specifications and product design without notice. Such revisions do not entitle buyer to corresponding changes, improvements, additions or replacements for previously purchased equipment. Information is not for design purposes.