

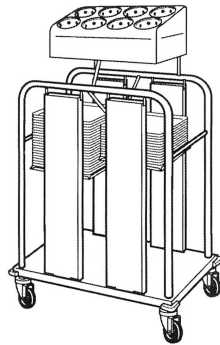

PTS/MO



PTS/MO2

PTS/MO AND PTS/MO2 SERIES

Piper's Self-leveling Mobile Tray and Silver Dispensers are offered in two styles; single or double stack. Each stack holds 150 trays. These Self-leveling Tray and Silver Dispensers can be found in tray lines, front- or back-of-the-house, or any place your needs require.

COMMON OPTIONS

<input type="checkbox"/>	011-3842	Silverware Cylinder, stainless steel Each
<input type="checkbox"/>	159-2701	Silverware Cylinder, plastic Each
<input type="checkbox"/>	341-3483	Napkin Dispenser, folded napkin 3.5"x7"
<input type="checkbox"/>	I	Silverware, identity plates (knives, forks, teaspoons) Each for Carts
<input type="checkbox"/>	PB	Full Perimeter Bumper (adds 2" to overall length and width)
<input type="checkbox"/>	WB	Two locking casters
<input type="checkbox"/>	Y4	Polyurethane 4
<input type="checkbox"/>	Y5	Polyurethane 5

JOB _____ ITEM # _____ QTY # _____

MODEL NUMBERS:

- PTS 915MO PTS 1520MO PTS 1222MO2
- PTS 1014MO PTS 1622MO PTS 1418MO2
- PTS 1216MO PTS 915MO2 PTS 1520MO2
- PTS 1222MO PTS 1014MO2 PTS 1622MO2
- PTS 1418MO PTS 1216MO2

DIMENSIONS:

- PTS 915MO - 52.625"H x 14.5"W X D
- PTS 1014MO - 52.625"H x 14.5"W X D
- PTS 1216MO - 52.625"H x 19.875"W X D
- PTS 1222MO - 52.625"H x 25.875"W X D
- PTS 1418MO - 52.625"H x 21.875"W X D
- PTS 1520MO - 52.625"H x 23.875"W X D
- PTS 1622MO - 52.625"H x 25.875"W X D
- PTS 915MO2 - 52.625"H x 25.125"W X D
- PTS 1014MO2 - 52.625"H x 25.125"W X D
- PTS 1216MO2 - 52.625"H x 32.5625"W X D
- PTS 1222MO2 - 52.625"H x 32.5625"W X D
- PTS 1418MO2 - 52.625"H x 36.5625"W X D
- PTS 1520MO2 - 52.625"H x 38.5625"W X D
- PTS 1622MO2 - 52.625"H x 40.5625"W X D

STANDARD FEATURES

- Equipped with self-lubricating delrin wheels and stainless steel extension springs that can be easily disconnected to adjust the lifting rate
- Self-leveling mechanism lifts out for easy cleaning
- Field adjustable to accommodate different weights
- Removable stainless steel carrier tray provides bottom support for trays being dispensed
- Base is fabricated from stainless steel and reinforced with stainless steel angles
- Tubular frames are fabricated from stainless steel tubing and securely welded to stainless steel angles on underside of base
- Frames are reinforced by horizontal stainless steel rods welded to each vertical frame
- Top-mounted stainless steel silverware holder (Does not include plastic silverware cylinders.)
- Non-marking bumper attached at each corner
- Four 4" heavy-duty non-marking swivel casters that are securely mounted to the base

WARRANTY

One year parts and labor. Warranty is detailed on inside front cover of the price list.

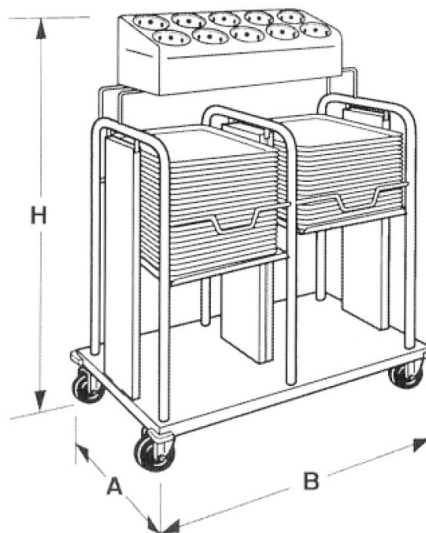
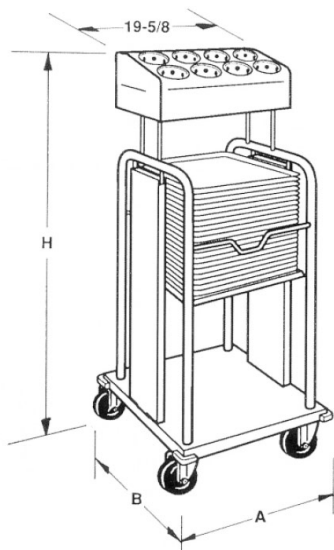

Model #	Max. Tray Size	(A) Length	(B) Width	Height	No. of Cylinders	Ship Wt. (lbs)
Single						
PTS 915MO	10.75" x 15.125"	18.5"	14.5"	52.625"	6	73
PTS 1014MO	10.75" x 15.125"	18.5"	14.5"	52.625"	6	73
PTS 1216MO	12" x 16"	16.6875"	19.875"	52.625"	6	73
PTS 1222MO	12.375" x 22"	16.6875"	25.875"	52.625"	6	80
PTS 1418MO	14" x 18"	18.6875"	21.875"	52.625"	8	78
PTS 1520MO	15" x 20"	19.6875"	23.875"	52.625"	8	84
PTS 1622MO	16" x 22"	20.6875"	25.875"	52.625"	8	84
Double						
PTS 915MO2	10.375" x 15.25"	19.375"	25.125"	52.625"	10	90
PTS 1014MO2	10.375" x 15.25"	19.375"	25.125"	52.625"	10	90
PTS 1216MO2	12.375" x 16.75"	19.875"	32.5625"	52.625"	10	108
PTS 1222MO2	12.375" x 22.75"	25.875"	32.5625"	52.625"	10	115
PTS 1418MO2	14.375" x 18.75"	21.875"	36.5625"	52.625"	10	97
PTS 1520MO2	15.375" x 20.75"	23.875"	38.5625"	52.625"	10	115
PTS 1622MO2	16.375" x 22.75"	25.875"	40.5625"	52.625"	10	119

SPEC E-11



The Food-Focused Equipment Company

300 S. 84th Avenue | Wausau, WI 54401
 Phone: 800-544-3057 | Fax: 715-842-3125
www.piperonline.net

LIMITED WARRANTY: PIPER PRODUCTS warrants to the original purchaser parts and labor for a period of twelve (12) months from the date of purchase. See manufacturer's complete warranty for details.

It is our policy to build equipment which is design certified by companies that have been accredited at the Federal Level by the Occupational Safety and Health Agency (OSHA) and ANSI as a National Recognized Testing Laboratory. These companies include CSA International, Underwriters Laboratories, and the National Sanitation Foundation. However, a continuing program of product improvement makes it necessary to submit new models to the agencies as they are developed. Consequently, all models may not bear the appropriate labels at all times. We reserve the right to change specifications and product design without notice. Such revisions do not entitle buyer to corresponding changes, improvements, additions or replacements for previously purchased equipment. Information is not for design purposes.