



210 with Racks

Piper's Open Racks provide strength and excellent versatility at an economical price. Featuring all-aluminum construction and welded panels, these racks have double-welded side glides for added strength and rigidity.

STURDY TRAY SUPPORTS

- .080" thick aluminum extruded glides
- 1" x 1.5" ledge angles
- Welded on front and back - twice as many welds as competitors

TIE BARS

- 1/2" extruded aluminum tie bar keeps rack square
- Adds rigidity and stability to rack
- Two per unit

WARRANTY

- One year parts and labor. Warranty is detailed on inside front cover of the price list.

JOB _____ ITEM # _____ QTY # _____

MODEL NUMBER:

- 208
- 210

DIMENSIONS:

- 208 - 69.135"H x 22.75"W X 22"D
- 210 - 69.135"H x 22.75"W X 22"D

HEAVY-DUTY CASTERS

- 5" x 1-1/4" sealed wheel stem casters
- Delrin bearing, each with 350 lbs. capacity
- Maximum resistance to chemicals, acids, bases, alcohol, water and steam
- Maximum low temperature flexibility for superior performance, even in freezing temperatures

COMMON OPTIONS

<input type="checkbox"/>	EMB	Personalized Embossment (12 letters per line - price per line) Per Line
<input type="checkbox"/>	PS	Pan Stop
<input type="checkbox"/>	R	Rotating Bumper (Adds 5)
<input type="checkbox"/>	V	Vertical Bumpers (adds 1)
<input type="checkbox"/>	WB	Two locking casters
<input type="checkbox"/>	Y5	Polyurethane 5

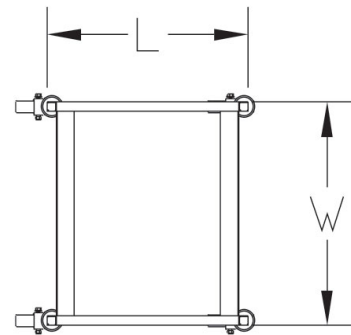
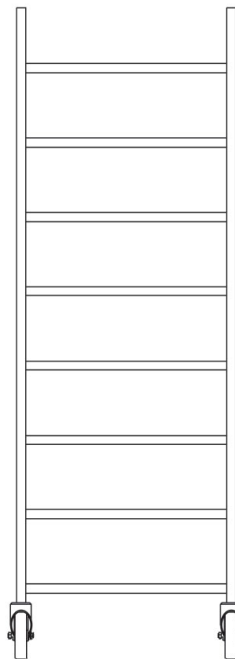
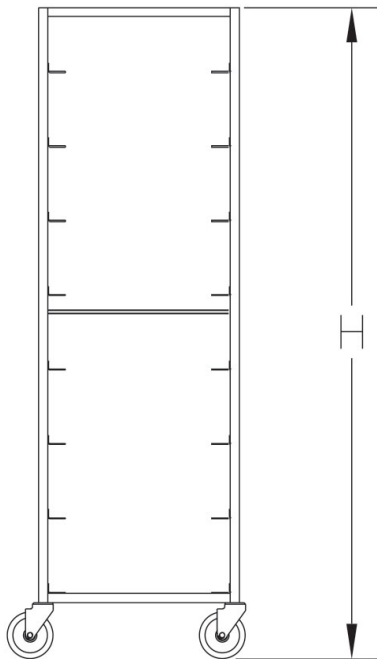

Model #	Description	Height Inches	Width Inches	Depth Inches	Channel Ht. Inches	Rack Capacity	Ship Wt. (lbs)
208	Aluminum Open Racks for 20" x 20" Cup or Glass Racks	69.135"	22.75"	22"	8"	8	35
210	Aluminum Open Racks for 20" x 20" Cup or Glass Racks	69.135"	22.75"	22"	6"	10	38

Height includes casters.

*Tabletop model does not have casters.

Approximate box dimensions: 66-1/2" x 27" x 5" Knock-down; 70" x 23" x 29" Welded

Typical freight class: 150

SPEC I-12

PIPER

The Food-Focused Equipment Company

300 S. 84th Avenue | Wausau, WI 54401
Phone: 800-544-3057 | Fax: 715-842-3125
www.piperonline.net

LIMITED WARRANTY: PIPER PRODUCTS warrants to the original purchaser parts and labor for a period of twelve (12) months from the date of purchase. See manufacturer's complete warranty for details.

It is our policy to build equipment which is design certified by companies that have been accredited at the Federal Level by the Occupational Safety and Health Agency (OSHA) and ANSI as a National Recognized Testing Laboratory. These companies include CSA International, Underwriters Laboratories, and the National Sanitation Foundation. However, a continuing program of product improvement makes it necessary to submit new models to the agencies as they are developed. Consequently, all models may not bear the appropriate labels at all times. We reserve the right to change specifications and product design without notice. Such revisions do not entitle buyer to corresponding changes, improvements, additions or replacements for previously purchased equipment. Information is not for design purposes.