

JOB _____ ITEM # _____ QTY # _____

MODEL NUMBER:

- 934-HU
- 1012U

DIMENSIONS:

- 934-HU - 68.875"H x 25"W X 31"D
- 1012U - 67.5"H x 31"W X 30.5"D

HEAT SYSTEM

- Individual heat and food moisture controls
- Digital read-out for accuracy
- Stainless steel 1 gallon water pan
- Unit removable for easy cleaning & maintenance
- 60 minute timer XR 120 volt, 12.5 AMP, 1500 Watts

HEAVY-DUTY CASTERS

- 5" diameter x 1 1/4" wide swivel sealed wheels
- 350 lb. capacity
- Maximum resistance to chemicals, acids, bases, alcohol, water and steam
- Maximum low temperature flexibility or superior performance even in freezing temperatures

COMMON OPTIONS

- Lexan full-view door
- Push handle
- Dutch doors
- Personalized embossment
- See reverse side for additional options

WARRANTY

One year parts and labor. Warranty is detailed on inside front cover of the price list.



PIPER'S SUPERIOR FOUNDATION

Featured on our toughest racks: Two 14 gauge aluminized steel reinforcing channels support our .090" thick aluminum bottom panel. The edges are formed and rolled to create a built-in bumper and heavy duty plate casters make this the strongest foundation in the industry.

1012-U

Piper's aluminum Heated Cabinets /Proofer are designed with features to make your operation efficient. Controls can be easily accessed at the front of the Cabinet without opening the doors and the entire heater unit can be removed for cleaning and maintenance.

STANDARD FEATURES

- Base is a solid bottom constructed of .125" aluminum, rolled edge base acts as a built-in bumper
- Two 14-gauge aluminized steel reinforcing channels attach the casters and support the bottom panel
- Frame consist of four extruded channels 1-1/2" x 5/8" x .094" aluminum. Corners have .190 channel supports for reinforcement
- Double pan top constructed of two .080" thick aluminum panels, fully welded corners
- Universal Glides are adjustable on 3" centers to accommodate various steam table and sheet pan sizes
- Door panel is .125" PVC coated aluminum attached to cabinet with bakery hinges, 270 degree door swing with card clip
- Back panel is .080" aluminum fully welded with removable multiple louvered vent stack
- 1/2" extruded aluminum tie bar keeps cabinet square
- 16-gauge stainless steel positive gravity latch is provided to keep door closed during transport
- Stainless steel side door latch holds door open XR One inch insulation surround the cabinet (Insulated models only)
- Card clip, easy identification of cabinet content when door is closed

TEMPERATURE PROFILE

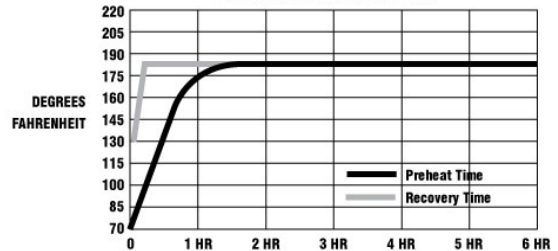

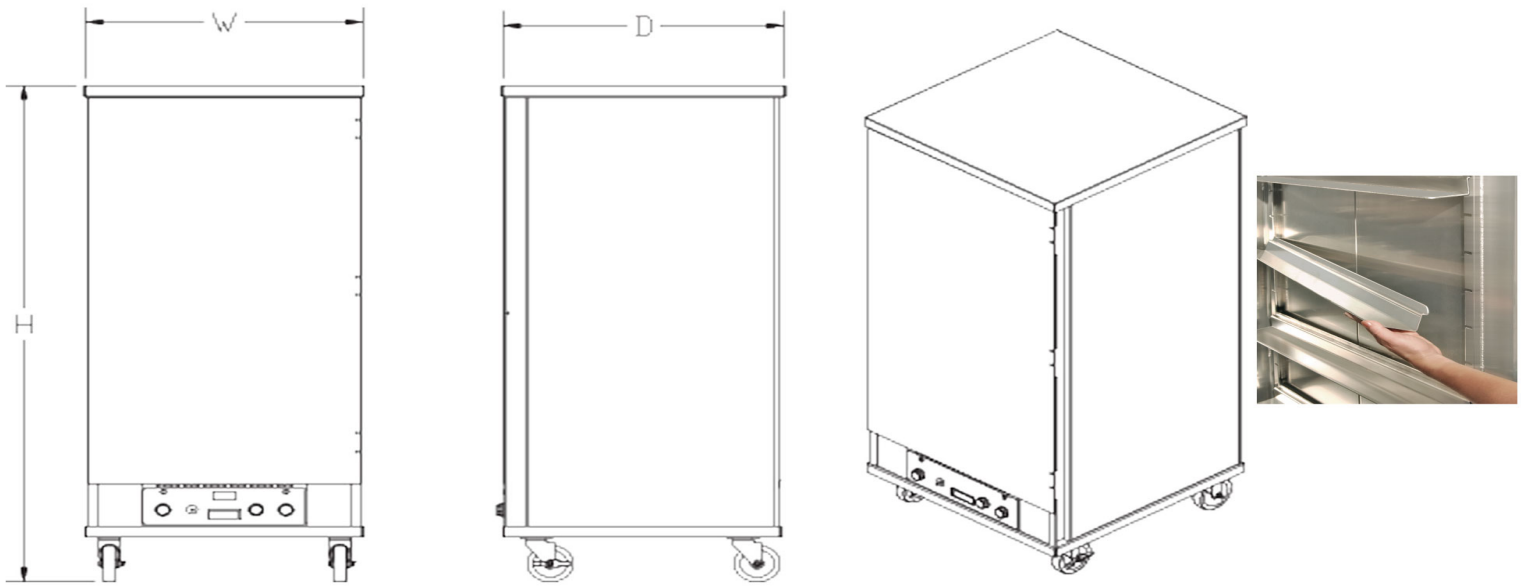

Pan glides are adjustable on 3 1/8" centers.
 Universal models shipped with 12 sets of glides, units can hold 16 sets
 All models 120 volt, 12.5 APM, 1500 watts

Model Number	Description	(A)Height	Width	Depth	Channel Spacing Inches	Pan Capacity	Ship Wt.(lbs)	Shipping Class
934-HU	Heated/Non-insulated, Universal Shelving	68.875"	25"	31"	3.125"	12	240	100
1012U	Heated/Insulated, Universal Shelving	67.5"	31"	30.5"	3.125"	12	260	100

COMMON OPTIONS	
<input type="checkbox"/> 5x2	Heavy-duty Casters (set of 4)
<input type="checkbox"/> B	Corner Bumper (adds 2" to overall length and width)
<input type="checkbox"/> CH	Chest Handles Per Pair
<input type="checkbox"/> CHT-2	Canned Heat Tray Insert
<input type="checkbox"/> CP	Correctional Package
<input type="checkbox"/> DD	Dutch Door
<input type="checkbox"/> EMB	Personalized Embossment (12 letters per line - price per line) Per Line
<input type="checkbox"/> FL	Floor Lock
<input type="checkbox"/> I	Insulated Transport Cabinet

COMMON OPTIONS	
<input type="checkbox"/> LD	Lexan Full-View Door
<input type="checkbox"/> LH	Locking Hasp
<input type="checkbox"/> PB	Full Perimeter Bumper (adds 2" to overall length and width)
<input type="checkbox"/> PH	Push Handle
<input type="checkbox"/> WB	Two locking casters
<input type="checkbox"/> PT	Pass-Thru Option (Not available on Heated Units)
<input type="checkbox"/> Y4	Polyurethane 4
<input type="checkbox"/> Y5	Polyurethane 5