

# PIPER

The Food-Focused Equipment Company

## 7QT AND 11QT ROUND WELL DROP-INS

Installation and Operating Manual



**For service information call 800-544-3057**

Please have the following information available before calling. Information can be found on the identification/certification tag:

- Model Number
- Serial Number
- Date of Purchase
- Part Description and number as shown in parts list



**IMPORTANT INFORMATION  
READ BEFORE USE**

This manual contains important safety information concerning the maintenance, use and operation of this product. Failure to follow these instructions could result in damaging equipment, voiding the warranty, serious injury or even death.

Piper Products, Inc  
300 South 84th Avenue  
Wausau, WI 54401  
Phone: 715-842-2724 . FAX: 715-842-3125

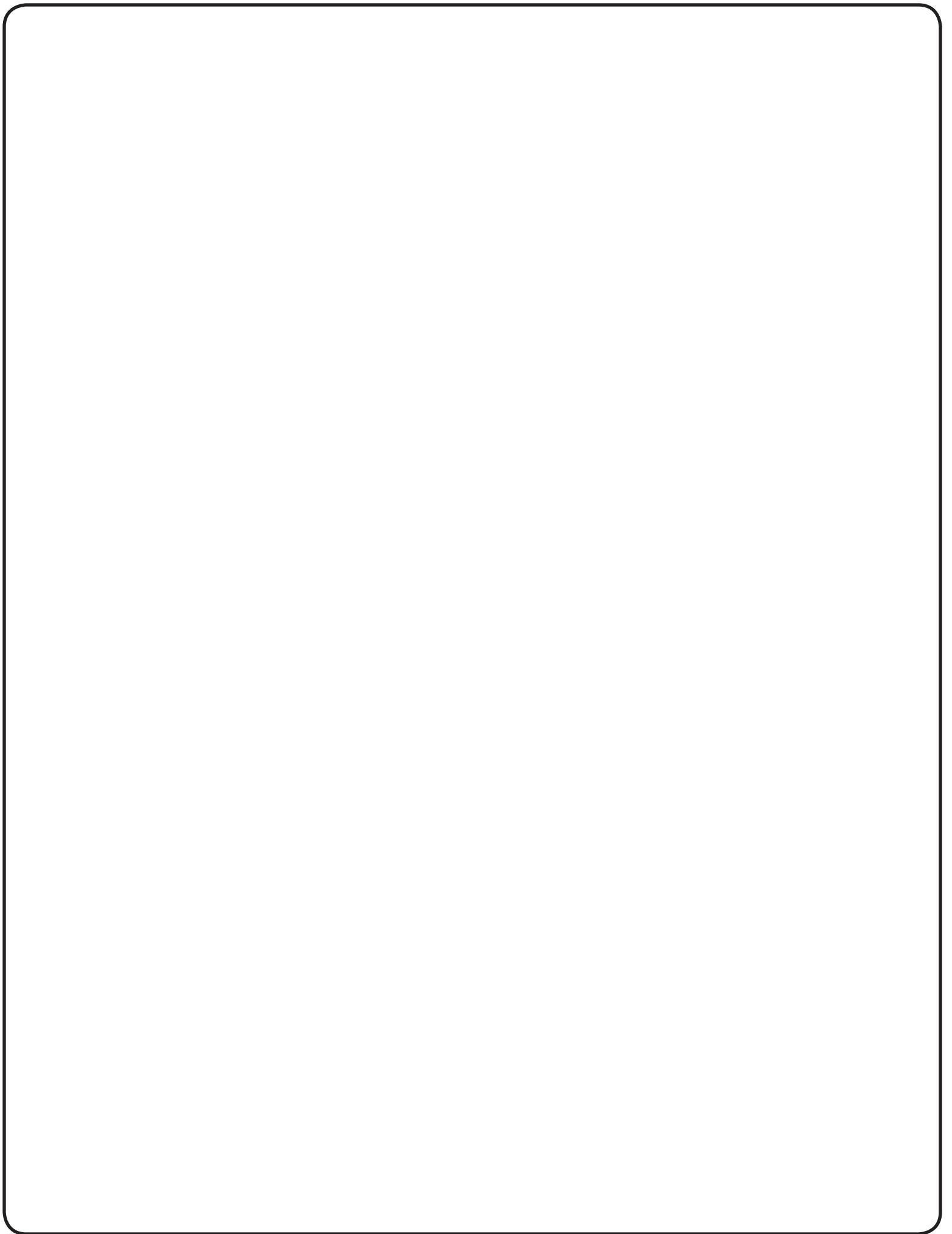

# TABLE OF CONTENTS

2	INTRODUCTION
2	FREIGHT DAMAGE CLAIMS
3	MODEL NUMBER DESIGNATIONS
3	ENGINEERING CONSIDERATIONS
3	CONDITIONS OF ACCEPTABILITY
4	INSTALLATION
5	CUTOUT DIMENSIONS
6	THEORY OF OPERATION
6	START-UP AND OPERATION
8	MAINTENANCE
9	GENERAL CLEANING
10	TROUBLESHOOTING GUIDE
11	PARTS BREAKDOWN
12	WIRING DIAGRAMS
13	WARRANTY

## INTRODUCTION

Congratulations! You have just purchased one of the finest pieces of equipment on the market today. Before installing or operating your new Piper equipment, you should read through this manual. This manual should be retained for further reference as it contains installation and operating instructions, service tips, parts list and warranty information.

**For your safety, read and follow all cautions and warnings.**

## FREIGHT DAMAGE CLAIMS

Your Piper equipment was carefully inspected and packed before leaving our factory. The transportation company assumes full responsibility for safe delivery of this equipment. Piper Products cannot assume responsibilities for damage or loss incurred in transit. Visible damage or loss should be noted on the freight bill and signed by the person making the delivery.

A freight claim should be filed immediately with the transportation company. If damage is unnoticed or concealed until equipment is unpacked, notify the transportation company immediately and tell them you want to file a concealed damage claim. This must be done within five (5) days after delivery was made. Be sure to retain all packing material and cartons.

### WARNING

Installation of this equipment should be done only by persons qualified or licensed to install electrical equipment. All electrical and plumbing must meet local, state, and federal codes.

Plumbing installation must be performed by a qualified plumber.

Adjustments and service work should be performed only by a qualified service technician. Service is available through Authorized Piper Parts and Service Distributors throughout the United States. For a complete listing of these call or write Piper Products, Inc. for the name of the nearest distributor.

This equipment is intended for commercial use only. Not for household use. Use of other than genuine Piper replacement parts or service work performed by other than an authorized Piper service agent will void the warranty.

Do not use any corrosive cleaners. Piper only approves soap and water for cleaning stainless steel.

## MODEL NUMBER DESIGNATION

MODEL NUMBER	VOLTAGE	WATTAGE	AMPS	WELL SIZE QUARTS	BASIC MODEL	BASIC WITH DRAIN
7QT-D-TR-120	120	300	2.5	7		X
7QT-OD-TR-120	120	300	2.5	7	X	
7QT-D-TR-208	208	300	1.4	7		X
7QT-OD-TR-208	208	300	1.4	7	X	
7QT-D-TR-240	240	300	1.3	7		X
7QT-OD-TR-240	240	300	1.3	7	X	
11QT-D-TR-120	120	300	2.5	11		X
11QT-OD-TR-120	120	300	2.5	11	X	
11QT-D-TR-208	208	300	1.4	11		X
11QT-OD-TR-208	208	300	1.4	11	X	
11QT-D-TR-240	240	300	1.3	11		X
11QT-OD-TR-240	240	300	1.3	11	X	

## ENGINEERING CONSIDERATIONS

The round hot food wells are for use only in commercial cooking appliances where Underwriters Laboratoris Inc determines the combination acceptable.

## CONDITIONS OF ACCEPTABILITY

When installed in the end-use commercial cooking appliance, following are among the considerations to be made”

1. The units may be mounted in a wood enclosure provided acceptable electrical enclosures are provided in accordance with Item 3 below and the clearances to combustibles as outlined in Item 2 below.
2. There must be a minimum clearance of 2 inches between the unit and the rear and side walls of the enclosure, 2-1/2 inches between the unit and the bottom of the enclosure, and 3-1/2 inches between the unit and the front of the enclosure panel containing the controls. There is no minimum clearance between adjacent units.
3. A metal enclosure, a minimum 0.026 inches thick, or listed flexible conduit must be provided to enclose wiring between the unit and the controls.
4. Quick-Connect terminals on the controls are not intended for field wiring.
5. The maximum temperature on the body of the pilot light shall not exceed 125°C in the end-use appliance.
6. These units are not provided with a grounding conductor to bond the kettle to the infinite switch cover. The final construction shall be such that an acceptable bonding path exists from both the kettle and the infinite switch cover to the equipment grounding terminal or lead of the final appliance.

# INSTALLATION



## ELECTRICAL CONNECTION

**WARNING!!!! DO NOT USE EXTENSION CORDS (VOIDS WARRANTY)**

### Ground:

The electrical outlet must be provided with an efficient ground, and the voltage and the frequency of the electrical line matches those indicated on the data plate.



If unsure about the efficiency of the ground, have your electrical circuit checked by a qualified electrician

- Carefully remove unit from carton or crate. Remove all loose packing materials, making sure that no small parts or accessories are lost. Inspect the unit for concealed damage before discarding packing materials.
- It is the responsibility of the installer to comply with all local codes.
- Check unit nameplate for electrical requirements. Make sure that the control knob is set to the "OFF" position. Connect the electrical power cord and plug to a properly sized power source of the correct voltage. See wiring diagram on page 12.
- Turn the control knob to the number 5 setting; pilot light will glow and the bottom of the well will start to warm. As soon as you notice heat turn the thermostat "OFF".



**CAUTION: Bottom of well will heat rapidly and may cause severe burns if touched. Well will turn a blue-black color due to the high heat produced when operated dry. This is normal and will not harm the well.**

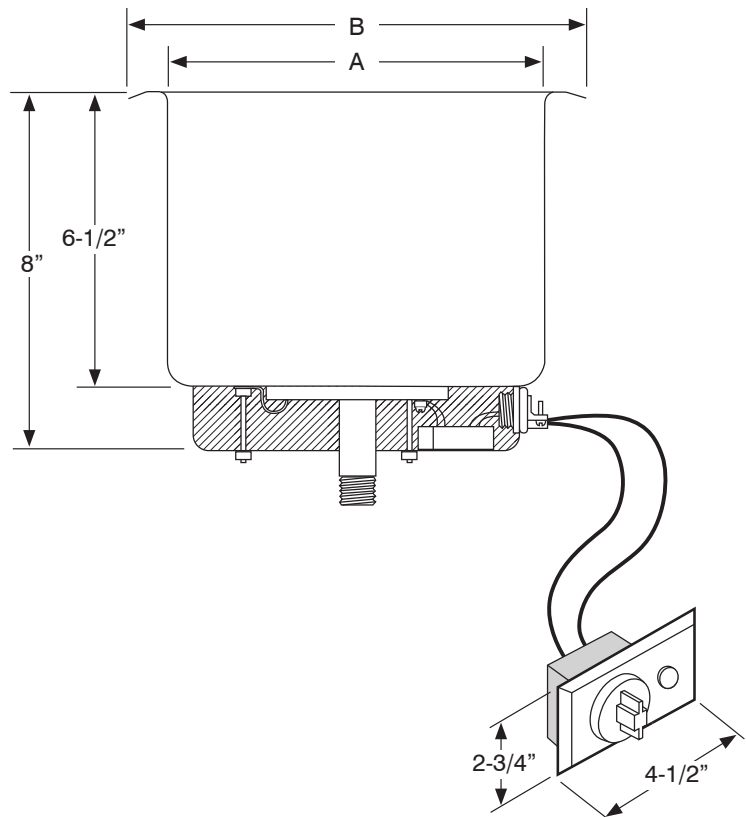

## CUTOUT DIMENSIONS

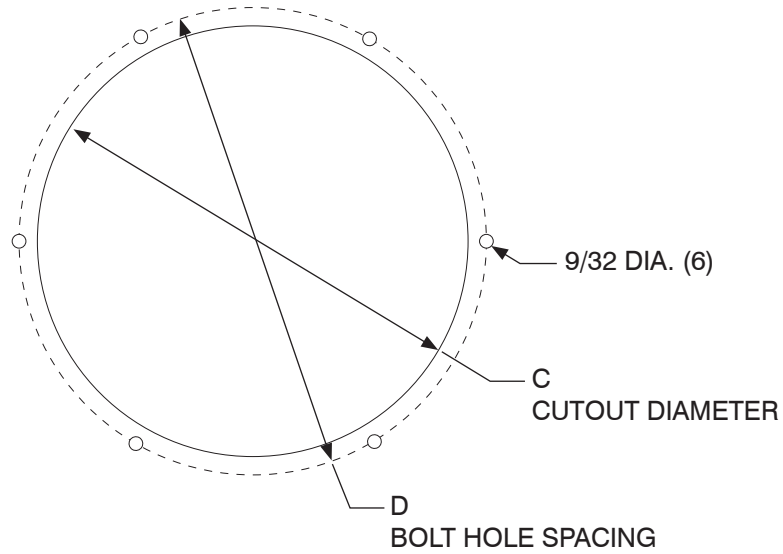

## COUNTER CUTOUT

DIMENSION	7QT SOUP WELL	11QT SOUP WELL
A	8-3/8"	10-3/8"
B	10-7/32"	12-9/32"
C	8-13/16"	10-11/16"
D	9-7/16"	11-5/16"

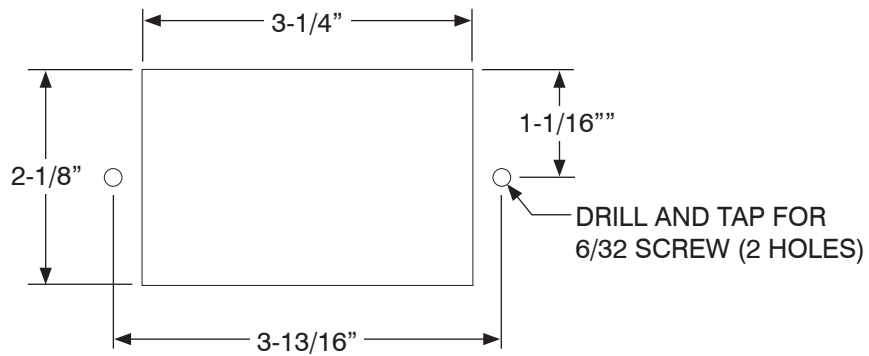

## CONTROL CUTOUT

## THEORY OF OPERATION

Hot food wells are designed to maintain prepared foods at a serving temperature of 140° to 160° Fahrenheit for one to two hours. They may be operated wet or dry depending on the type of food being served. **NOTICE:** When operated dry the stainless steel well will discolor due to the high heat.

Each individual well is controlled by a positive off adjustable thermostat or infinite control switch. The knob is marked with an off position and numbered from 1 through 10 with 1 being the lowest setting and 10 being the highest. These numbers do not relate to a set temperature as this will vary due to the ambient conditions and different types of operation.

## START-UP AND OPERATION

### DRY OPERATION

- Make sure that the well is empty and clean. Place cover over well. Turn control knob to the number 10 setting and allow to pre-heat for approximately 30 minutes. After 30 minutes turn knob back to the number 6 or 7 setting until food is placed into well.

**NOTICE:** Well will turn a blue-black color due to the high heat produced when operated dry. This is normal and will not harm the well.

- Uncover food well and place pan of prepared food into the well. **NEVER** place food directly into food well. Temperature of food being placed into food well must be 160° Fahrenheit minimum. Turn control knob to desired operating setting. This setting will vary according to room conditions and type of food being served.



**CAUTION: Never add water to a HOT food well that has boiled dry or has been operated dry. This will cause damage to the well. Allow pan to cool before adding water.**

- Always keep food pans covered when not serving. Change pans of food often to insure that proper serving temperature is maintained.



## WET OPERATION

- **IMPORTANT:** Make sure that food wells are at room temperature and that each well is empty and clean. If the well is equipped with optional drain be sure that drain valve is closed.
- Fill well with HOT tap water to the water fill mark located at the end of the well. Approximately 3/4" of water. Cover the well using a tight fitting cover or food pan.
- Turn control knob to the number 10 setting and allow well to pre-heat for approximately 45 minutes.
- Uncover food well and place pan of prepared food into the well. NEVER place food directly into wells. Temperature of food being placed into the well must be 160° Fahrenheit minimum. Turn control knob to desired operating setting. This setting will vary according to room conditions and type of food being served.
- Periodically check the water level in the well. It is very important that food wells not be allowed to boil dry. When approximately one half of the water has boiled off, hot tap water should be added to bring water level up to the fill mark.



**CAUTION: Never add water to a HOT food well that has boiled dry or has been operated dry. This will cause damage to the well. Allow pan to cool before adding water.**

- Always keep food pans covered when not serving. Change pans of food often to insure that proper serving temperature is maintained.
- After the serving period turn control to "OFF" position and allow well to cool before cleaning.
- Always drain or remove water from well after each meal. If unit is equipped with drain, place a bucket under the drain pipe and open drain valve. When bucket is full, close drain valve and empty bucket.
- Clean with a soft cloth or sponge and a mild detergent. Rinse completely with warm water and then dry.
- A plastic scouring pad and a mild detergent may be used to remove any hardened food or scale deposits.

**NOTICE: Do not use steel wool to clean wells.**

- Use a soft cloth or sponge with a mild detergent to clean all exposed surfaces of the well. Rinse completely with warm water and dry.

## MAINTENANCE

To obtain the best performance from your equipment, it should be cleaned daily and maintained in good condition.



### SAFETY / ENVIRONMENTAL CAUTION

#### PERSONAL PROTECTION:

Check your company safety and environmental policy before cleaning or servicing.



**Safety Tip!** : Utilize protective gloves and safety glasses

#### ELECTRICAL POWER:



Before performing EXTENDED CLEANING where electrical components can become wet, the power switch must be turned to OFF and the unit disconnected from the power source.



**WARNING:** Do not use any chlorinated or highly caustic cleaners, acids, ammonia or other corrosive cleaners. These may cause corrosion and/or damage to the stainless steel. Piper only approves soap and water for cleaning stainless steel. Do not allow water to stand in wells for long periods of time. Well must be emptied and cleaned after every serving period.

#### REQUIRED MONTHLY MAINTENANCE:

- Check control settings
- Check operating temperature of unit
- Check and clean drainage lines
- Check electrical connection

## GENERAL CLEANING



**CAUTION: BURN HAZARD:** Some exterior surfaces on unit will get hot. Use caution when touching these areas.

**DO NOT** clean the unit while it contains any food product. Remove food product and allow unit to cool completely before cleaning or servicing.

**CAUTION:** Prior to cleaning or maintenance, turn all switches “OFF” and disconnect the power.

All food wells should be cleaned daily.

### **Stainless Steel and Aluminum:**

- Piper only approves soap and water for cleaning stainless steel.
- **NOTICE: Do NOT use chlorinated cleaners.**

### **General Surfaces, Fiberglass:**

- Clean surfaces with a soft cloth or sponge utilizing a mild detergent. Rinse completely with warm water and then dry.
- **NOTICE: Do NOT use steel wool**

### **Hardened Foods or Scale Deposits:**

- Clean hardened foods or scale deposits by utilizing a plastic scouring pad and a mild detergent. Rinse completely with warm water and dry.
- **NOTICE: Do NOT use steel wool**

## TROUBLESHOOTING GUIDE

If problems are not found by the following checks, then you should contact your Authorized Parts and Service Dealer for service. They have the necessary parts and training to repair your unit quickly and efficiently.



**DANGER:** Disconnect all power to unit before servicing.

SYMPTOMS	POSSIBLE CAUSE	REMEDIES
Pilot light is off, pan does not heat.	No electrical supply	Is the unit plugged in?
		Check circuit breaker and fuse.
		Check switch on control panel is in "ON" position.
		Call a service technician.
Pilot light is on but wells not heating	Temperature control	Is the temperature control set properly?
Unit does not heat to proper temperature	Too much water	Wells should have about 3/4" of water in them.
	Not pre-heated	Has the unit been allowed to pre-heat for at least 30 minutes with lids on?
	Temperature control	Is the temperature control set properly?
	Voltage	Call a service technician.
Does not maintain temperature	Water level	Wells should have about 3/4" of water in them.
	Food longer than 2 hours	Food should not be kept in HF units for long periods of time.
	Not Pre-heated	Has the unit been allowed to pre-heat for at least 30 minutes?
	Food Temperature	Were pans of food placed into the unit at or above 160°?
	Temperature Control	Is the temperature control set properly?
	Voltage	Call a service technician.

**Call Piper Products directly at 800-544-3057 if you need further assistance.**

## PARTS BREAKDOWN

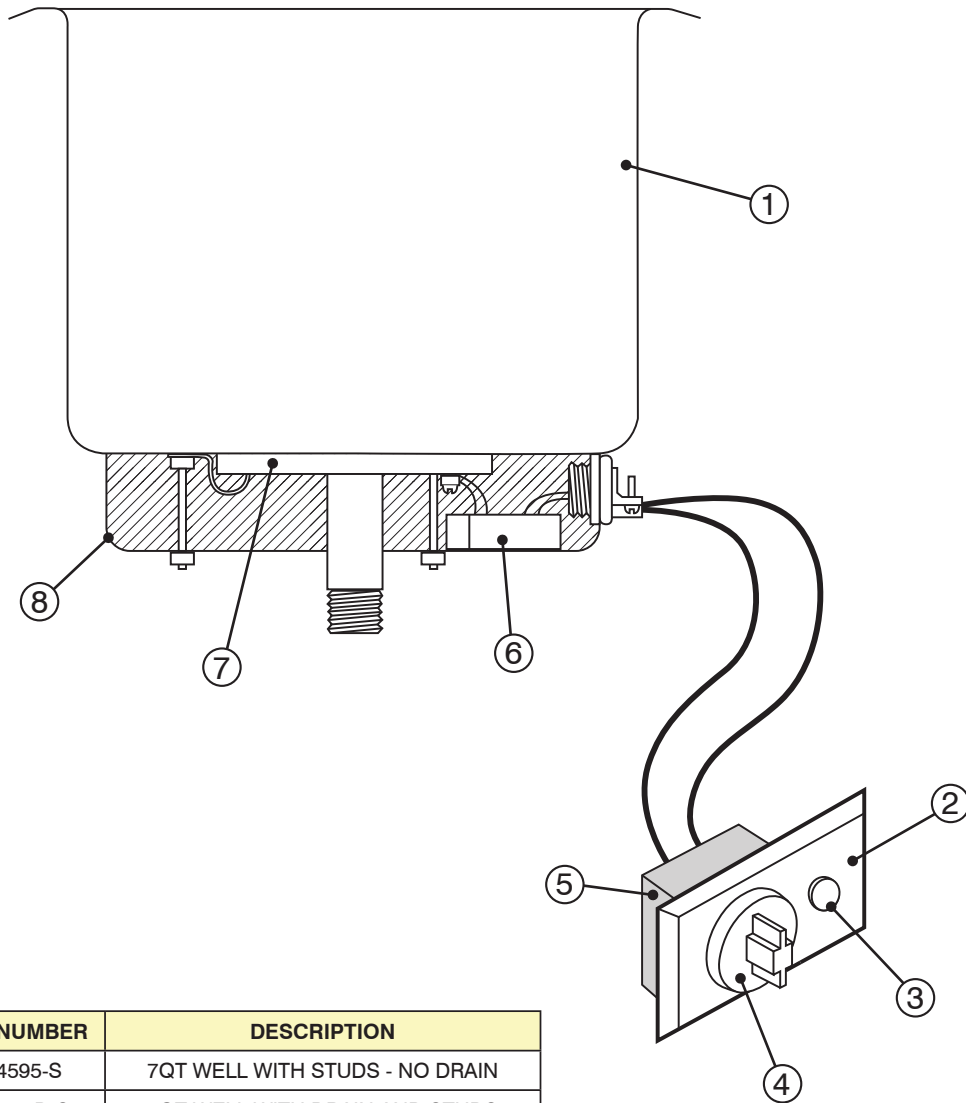

ITEM NO.	PART NUMBER	DESCRIPTION
1	0624595-S	7QT WELL WITH STUDS - NO DRAIN
	0624595D-S	7QT WELL WITH DRAIN AND STUDS
	0624590-S	11QT WELL WITH STUDS - NO DRAIN
	0624590D-S	11QT WELL WITH DRAIN AND STUDS
2	076507	MOUNTING PLATE
3	0189500	INDICATOR LIGHT
4	0178525	KNOB - INFINITE CONTROL
5	0083100	INFINITE CONTROL - 120V
	0083150	INFINITE CONTROL - 208V
	0083200	INFINITE CONTROL - 240V
6	0350250	HI-LIMIT THERMOSTAT
7	0346090	HEATER - 120V
	0346091	HEATER - 208V
	0346091	HEATER - 240V
8	0907142	COVER PAN

# ELECTRICAL DATA

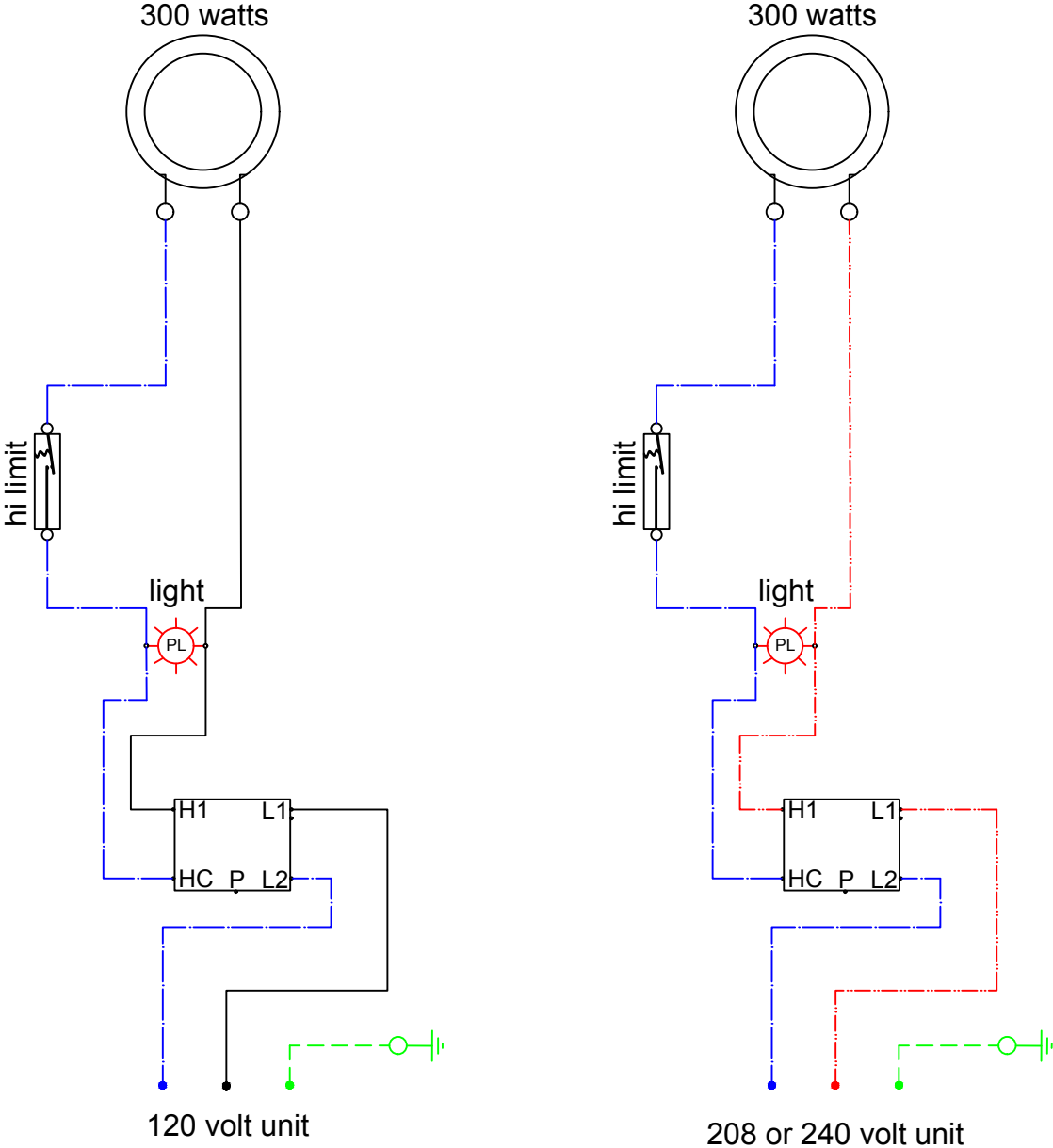

**WARNING:** Adjustments and service work must be performed only by a qualified service technician. Install to comply with all local and national electrical codes. Service is available through Authorized Piper Parts and Service Distributors throughout the United States. For a complete listing of these visit [www.piperonline.net](http://www.piperonline.net) or call Piper for the name of the nearest distributor.

## PIPER PRODUCTS, INC. LIMITED WARRANTY

Piper Products, Inc. warrants to the original purchaser that its equipment will be free from defects in the materials and/or parts for a period of 12 months from date of shipment and reported to the factory.

The purchaser is responsible for having equipment properly installed, operated under normal conditions with proper supervision and to perform periodic preventative maintenance. Equipment failures caused by inadequate water quality, improper cleaning, harsh chemicals, or acids are not covered under warranty.

The manufacturer's obligation under this warranty shall be the replacement or repair of defective parts within the warranty period. Excessive labor (more than 1/2 hour) required to access Piper equipment built into cabinets, tables or structures by others, is NOT covered under labor warranty. Example: Piper multiple- or single-well food wells. All labor shall be performed during regular working hours. Overtime premium will be charged to buyer. After thorough examination, the decision of the Piper Products Service Department shall be final.

Any defective parts to be repaired or replaced must be returned to Piper Products, Inc., 300 South 84th Avenue, Wausau, WI 54401, transportation charges prepaid, and they must be properly packed and tagged. The serial and model number of the equipment and date of original installation of such equipment must be given. However, after one year we will not assume any responsibility for any expenses (including labor) incurred in the field incidental to the repair or replacement of equipment covered by this warranty. Our obligation hereunder to repair or replace a defective part is the exclusive remedy for breach of this warranty; and we will not be liable for any other damages or claims, including consequential damages.

If, upon inspection by Piper Products, Inc. or its Authorized Service Agency, it is determined that this equipment has not been properly installed or has not been used in an appropriate manner, has been modified, has not been properly maintained, the warranty will be void. Also, if the nameplate or other identifying marks have been removed, defaced or changed or the unit has been repaired or altered by persons other than expressly approved by Piper Products, Inc., the warranty will be void. If the equipment has been subjected to misuse or misapplication, neglect, abuse, accident, damage during transit or delivery, fire, flood, riot or acts of God, then this warranty shall also be void. When any situation occurs which voids the warranty the manufacturer shall not be liable for any damage to any person or any property which may result from the use of the equipment thereafter.

Warranty is limited to Piper manufactured products only and does not apply to other equipment which may be connected to or installed within.

No representative, dealer, distributor or any other person is authorized or permitted to make any other warranty or obligate Piper Products, Inc. to any liability not strictly in accordance with this policy.

This warranty is in lieu of all other warranties expressed or implied, including any warranty of merchantability, and fitness for a particular purpose. Piper Products does hereby exclude and shall not be liable to purchaser for any consequential or incidental damages including but not limited to damages to property, damages for loss of use, loss of time, loss of profits or income, resulting from any breach of warranty.

# **PIPER**

The Food-Focused Equipment Company

Piper Products, Inc  
300 South 84th Avenue  
Wausau, WI 54401  
Phone: 715-842-2724 . FAX: 715-842-3125